



Volume XXXIX
Number 2
Spring 2019



CONTENTS:

TWO LOCAL DEPARTMENTS DARE TO TAKE ON THE BIG JOBS.....1

2019 SPRING WORKSHOPS.....4

2019 ENGINEERING WORKSHOPS.....5

PREVENTING SEXUAL HARASSMENT IN THE WORKPLACE.....6

THE ROAD TO HIGHWAY SCHOOL.....9

ADVENTURES OF THE HIGHWAY SUPER.....11

Nuggets & Nibbles is available online!

clrp.cornell.edu/nuggets_and_nibbles

Two Local Highway Departments Dare to Take on the Big Jobs



Adam Howell, Communications Specialist

Good planning and budgeting are important for keeping a highway department on track but there are always surprises. Maybe unplanned problems come in the form of a critical piece of equipment failing unexpectedly, or a natural disaster striking. When big problems happen, safety and cost are two competing pressures that often intersect.



Rathburn Road Bridge, Town of Oswego Walmore Road Culvert, Town of Wheatfield

Despite the obvious challenges posed by unforeseen calamities, there are also great opportunities that can present themselves for local departments willing (and able) to step up to the challenge. Increased credibility with constituents, experience, and the pride that comes from going above and beyond the regular call of duty are all potential rewards. In this article we are going to look at two town highway departments that each decided to take on a big project which, in the end, reaped big benefits for their communities and their own departments.

Town of Oswego Rathburn Road Bridge Replacement

Town of Oswego Highway Superintendent David Sterio had a big problem on his hands when it came to a town bridge on Rathburn Road over Rice

Creek. In 2015 the town had been issued a yellow flag warning for the bridge by the New York State Department of Transportation (NYSDOT) due to deteriorations in the bridge structure. This yellow flag warning was subsequently followed by a red flag issuance by NYSDOT in 2016.

Apart from the significant deterioration in the bridge structure itself, there were several problems associated with the original design and the surrounding terrain. The flat watershed tributary to the structure meant that there was a consistent large volume of water draining through the area. Ultimately, following the completion of a hydraulic and hydrologic (H&H) study, it was found that the bridge would have to be totally replaced instead of just being rehabilitated due to the structure not meeting current design standards for flood resiliency.

When the scope of the project was finally realized and the costs were tallied, the overall approximate estimate to replace the bridge was \$440,000. The large price tag was more than the town could reasonably handle, so some sort of alternative solution had to be found. Even though a bridge replacement project was much more than what his team was used to managing, Superintendent David Sterio decided to see whether they could step up and help the town save money on the project. "I scratched my head and thought about whether we could cut costs by doing this ourselves," David says. "I got my own estimates, figured out the budget and decided that we could take this on." David was right, his budget of only \$240,000 included savings from the highway department acting as their own general contractor and using the department's own labor force and equipment for as much as the project as possible.

When David decided that the highway department would manage the project, he knew that he would



be entering some uncharted territory since his department had not taken on anything of this scope before. Good planning and utilizing partnerships would be important to the success of the project. "If you're going to build something, you have to have a good set of blueprints and a good set of specs," David says. "I relied a lot on our engineers who were very helpful. We also drew on some guys here who had experience in things like concrete work." Good planning also became critical to helping David save as much money as possible. Cost comparisons, using department labor when possible, and sending everything that couldn't be done in-house out to bid helped the department stay on budget.



In the end, the project was a huge success for the highway department and the town. The department came in right on budget and saved the town over \$200,000. For their efforts, the Town of Oswego Highway Department was honored for their work on the Rathburn Bridge project with the



From left to right: Town of Oswego Supervisor Richard Kauffuss; Town of Oswego Highway Superintendent David Sterio; and BCA Architects and Engineers Representative Casey Dickinson.

Transportation Project of the Year Award by the American Public Works Association. Looking back on the project, David has some honest advice for others who might be thinking about taking on a project that is a little more than what they are used to. “I don’t want to tell people to be afraid of anything because you don’t want to get in trouble by taking on more than you can handle, but you also can’t be afraid of trying new things. In the end, if you take on something like this, you need to roll up your sleeves, get to work, and get the job done.”

Town of Wheatfield Walmore Road Culvert Replacement

Paul Siegmann, the Town of Wheatfield Highway Superintendent learned in the Spring of 2016 that a large culvert in his town on Walmore road was in bad shape. “The culvert was shot, and the road wasn’t safe,” Paul remembers. “This was one of the main roads for the school district to drive on and to contract it out would have taken too long.....also the town wasn’t in a position to bond out the project because of previous project bonds they had issued.” This familiar meeting of fiscal stress and critical infrastructure inspired Paul to consider having the highway department replace the culvert themselves. The barriers to undertaking a larger project are

often different for each department. Sometimes the availability of equipment or the experience of the staff make larger projects difficult, for Paul it was the permitting process. “I pushed myself on this one,” Paul says. “I have been here for about 25 years and I remember that when I first started we used to do projects like these on our own. Over time though, it seems like things have become more difficult with permitting.”

In the Town of Wheatfield’s case, there were some welcome surprises that came from their experience with working on the Walmore Road culvert project. The permitting process was much easier to get through than anyone expected. “Don’t be afraid to talk to people like the DEC and the Army Corps,” Paul explains. “We made the calls and I did the drawings myself. They all worked with me and I was really surprised by how well.”



Once again, good planning and communication were the keys to a successful project. The local water department was instrumental in helping relocate a water pipe and local businesses located in an industrial park down the road had to be contacted regarding the temporary disruption due to the work. “It’s all about communication, if you give them enough time they will usually work with you,” Paul says.

Continued on Page 8

2019 CLRP Spring Workshops

Amanda Link, Event Coordinator



We still have space in 15 of our workshops. Check out the list below to see where space is available.

We realize that your time is valuable and, as always, we try to host at least one of our workshops within an hour's drive of your municipality.

Register for our spring workshops with the form found in this newsletter or online at <https://cornell.app.box.com/v/spring2019>

Asphalt Paving Principles

4/23/19 Clinton County - **Waitlist**

4/24/19 Saratoga County - **Waitlist**

4/25/19 Ulster County - **Waitlist**

5/14/19 Oswego County

5/15/19 Yates County

5/16/19 Erie County

Roadway and Roadside Drainage

4/23/19 Orleans County

4/24/19 Seneca County

4/25/19 Broome County

5/14/19 Schoharie County

5/15/19 Washington County

5/16/19 St. Lawrence County

Identifying and Reducing Legal Liability

4/16/19 Suffolk County

4/17/19 Dutchess County - **Waitlist**

4/18/19 Delaware County

Surveying

5/7/19 Wyoming County - **Waitlist**

5/8/19 Tioga County

5/9/19 Sullivan County

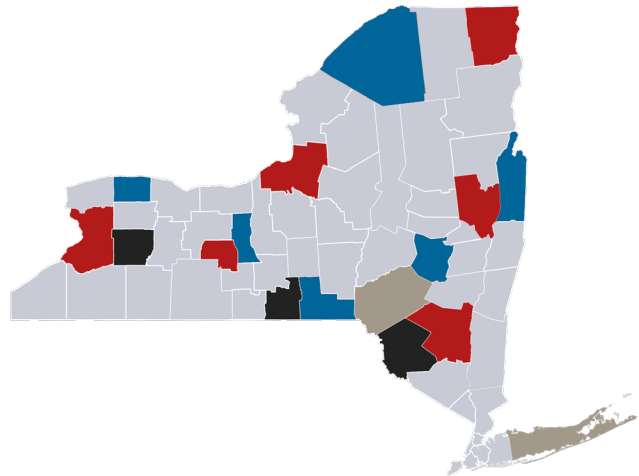

Asphalt Paving Principles

Roadway and Roadside Drainage

Legal Liabilities

Surveying

You can also request a workshop to be held outside of our regular schedule. Contact Amanda Link at ael234@cornell.edu or 607-255-5437 to learn more.

To learn more about our spring workshops including specific locations, visit <https://www.clrp.cornell.edu/workshops/workshops.htm> and click on the class title you are interested in.

2019 CLRP Engineering Workshops

Amanda Link, Event Coordinator



Our 2019 Engineering Workshop schedule is out and we are now accepting registrations!

The cost to attend an engineering workshop is \$75.00, PDH credit hours are an additional \$20.00. Remember, attendees must stay for the entire workshop in order to earn their PDH's.

To register for 2019 Engineering Workshops, use the registration form included in this newsletter or download it online at <https://cornell.app.box.com/v/Engineering2019>

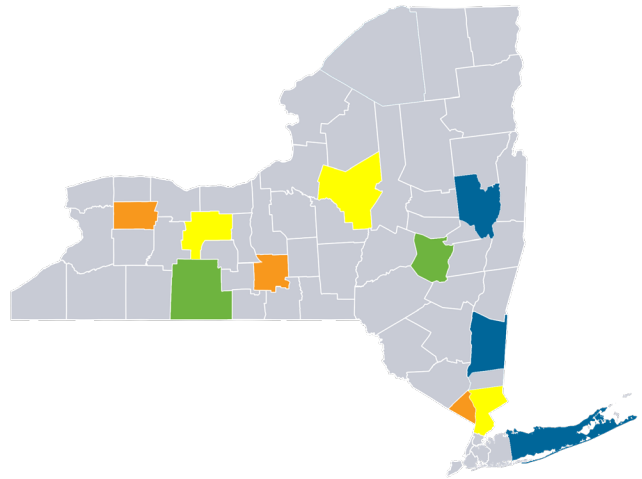

Design and Maintenance of Slopes Using Geosynthetics - 8 PDHs

- 7/16/19 Ontario County
- 7/17/19 Oneida County
- 7/18/19 Westchester County

Hydraulic Design of Culverts - 7 PDHs

- 6/18/19 Steuben County
- 6/19/19 Schoharie County

ADA in the Public Right-of-Way - 7 PDHs

- 8/6/19 Saratoga County
- 8/7/19 Dutchess County
- 8/8/19 Suffolk County

Low-Volume Road Pavement Design - 7 PDHs

- 10/8/19 Genesee County
- 10/9/19 Tompkins County
- 10/10/19 Rockland County



Hydraulic Design of Culverts

Design and Maintenance of Slopes using Geosynthetics

Americans with Disabilities Act in the Public Right of Way

Low-Volume Road Pavement Design

To learn more about the content and specific locations of this year's engineering workshops, visit <https://www.clrp.cornell.edu/workshops/engineer.html>

Preventing Sexual Harassment in the Workplace is Everyone's Job

John Mancini, NYCOM Council



Note: This article was originally published in the Fall 2018 edition of the New York Conference of Mayors (NYCOM) quarterly magazine "Municipal Matters"

As part of the fiscal year 2018-2019 New York State Budget, Governor Cuomo signed into law what has been described by some as one of the nation's strongest and most comprehensive sexual harassment laws.² The new law applies to both the public and the private sector. Employers are now required to have a comprehensive sexual harassment prevention policy in place and must provide mandatory training to all employees on an annual basis. To assist employers in meeting these new requirements the State has produced a Sexual Harassment Prevention Employer Toolkit. The toolkit can be accessed at: <https://www.ny.gov/sites/ny.gov/files/atoms/files/SexualHarassmentPreventionToolkitforEmployers.pdf>.

Mandatory Sexual Harassment Prevention Policy

The new law includes certain minimum standards that may be more comprehensive than some previously adopted municipal policies. Under the new law, effective October 9, 2018, all employers are required to have a sexual harassment prevention policy that meets or exceeds the new State minimum standards in place.

To assist employers in meeting the minimum standards imposed by the State, a "model" policy was established by the NYS Department of Labor in consultation with the State Division on Human Rights. The model policy can be found at: <https://www.ny.gov/combating-sexual-harassment-workplace/employers>.

Employers are not required to adopt the State's model policy. Employers can elect to adopt their own policy. However, if an employer chooses not to use the model policy provided by the State, then they must be sure that their policy meets or exceeds the new minimum standards.

In order to be legally compliant, sexual harassment prevention policies **at a minimum**, must:

- Prohibit sexual harassment consistent with guidance issued by the Department of Labor in consultation with the Division of Human Rights;
- Provide examples of prohibited conduct;
- Include information concerning the federal and state statutory provisions concerning sexual harassment, remedies available to victims of sexual harassment, and a statement that there may also be local laws that address sexual harassment;
- Include a complaint form;
- Include a procedure for the timely and confidential investigation of complaints that ensures due process for all parties;
- Inform employees of their rights of redress and all available forums for adjudicating sexual harassment complaints both administratively and judicially;
- Clearly state that sexual harassment is considered a form of employee misconduct and that sanctions will be enforced against individuals engaging in sexual harassment and against supervisory and managerial personnel who knowingly allow such behavior to continue; and

- Clearly state that retaliation against individuals who complain of sexual harassment or who testify or assist in any investigation or proceeding involving sexual harassment is unlawful.³

If your municipality's current sexual harassment prevention policy does not include all of the above-mentioned items the municipality should move swiftly to amend or adopt a new sexual harassment prevention policy that complies with State law.

Distributing Copies of the Policy

It is not enough to just have a sexual harassment prevention policy. Employers are also responsible for ensuring that all employees receive a copy of the policy in writing. Employers may comply with this requirement by distributing hard-copies of the policy to every employee or by sending electronic versions of the policy via email. The State has advised employers that if the policy is distributed electronically, the employee must have the ability to print a copy for their own records if they choose.⁴

Additionally, employers should have their employees acknowledge receipt of the policy.⁵ This acknowledgement should be included in the employee's personnel file.

Finally, copies of the policy should be posted in locations where employees can easily find them, including on the municipal website or intranet.

Mandatory Annual Training: It's the Law!

Municipal employers have until October 9, 2019 to provide sexual harassment prevention training to all employees of the municipality, including temporary, seasonal and part-timers.⁶ Furthermore, although not explicitly clear, it is NYCOM's opinion that the spirit and intent of the law also extends to municipal volunteers who exercise municipal authority.

For example, this could include village boards, city councils, volunteer fire fighters, and planning board and zoning board members. After the initial training, employers are mandated to provide sexual harassment prevention training on an annual basis. The training can be "based on calendar year, anniversary of each employee's start date or any other date the employer chooses."⁷ New employees must be trained as "quickly as possible" ⁸ after starting employment.

Training: It Must Be Interactive

In order to be compliant with the State's minimum standards, sexual harassment training must have the following components:

- Be interactive (see the model training guidance document for specific recommendations);
- Include an explanation of sexual harassment consistent with the guidance issued by the Department of Labor;
- Include examples of unlawful sexual harassment;
- Include information concerning employees' rights of redress and all available forums for adjudicating complaints; and
- Include information addressing conduct by supervisors and additional responsibilities for supervisors.⁹

The "interactive" training component can be accomplished in several ways. For example, municipalities may choose to conduct live-in-person training sessions, webinars or individual one-on-one training sessions. Regardless of the method of employed, the training must be interactive.

To assist employers, the State has produced a number of training aids municipal employers may utilize in order to comply with the annual training

Continued on Page 10

Continued from Page 3

In August of 2016, the Wheatfield Highway Department successfully completed the culvert replacement. The highway department closed the road and undertook most of the work on a Saturday to lessen the disruption to the flow of traffic. Overall the project was successful with limited traffic flowing after the main culvert pipe was installed. The total cost of the project was under \$40,000 which included not only the new culvert but also a widening of the bridge from 23 ft. to 40 ft. which allowed for both heavier commercial traffic to pass over the bridge and a safer traverse for the public.

Challenge Accepted

Both the Town of Oswego and Town of Wheatfield Highway Departments decided that it was worth it for them to undertake these larger, less familiar projects for their town. The similarities between their approaches is striking and highlights what it takes to be successful. Both town superintendents communicated with all the



stakeholders and put together a good plan before proceeding. Both departments built upon the already good relationship they had with their town and town boards to leverage support. Finally, both departments were able to push through and achieve each of those big, often conflicting goals of improving safety and saving money for their communities.

Of course, every municipal highway department

situation is different. Different expertise and the experience levels of employees, the availability of equipment or other department pressures may mean that contracting out bigger jobs makes more sense and, in certain situations, is even more cost effective when everything is considered. All local highway and public works departments innovate and take on more in a variety of different ways and part of running a department means making decisions that are right for your community. The important thing is knowing what is right for you and that every now and then, it can be worth it to take on a new challenge.

Resources:

Army Corps of Engineers NY District Permitting Webpage

<https://www.nan.usace.army.mil/Missions/Regulatory/Obtaining-a-Permit/>

Upstate NY Field Office Phone Numbers:
518-266-6350 (Permits Processing Team)
518-266-6360 (Permits Compliance & Enforcement)

New York Department of Environmental Conservation Permitting

<https://www.dec.ny.gov/permits/363.html>

Phone Number: 518-402-9167

Town of Oswego Highway Department Wins Transportation Project of the Year Award

Oswego County Today

<https://oswegocountytoday.com/town-of-oswego-highway-department-wins-transportation-project-of-the-year-award/community/>

Wheatfield Culvert Replacement by Paul Siegmann, Town of Wheatfield Highway Superintendent

Summer 2017 Edition of Town Highway Lines

The Road To..... Highway School

David Orr, PE, Director



This year's Highway School is set for June 3-5 in Ithaca. I have had folks ask many times why we hold the School at Ithaca College rather than at Cornell. The School was held at Cornell until 1987, when the hotel on campus (and the home to the School) was replaced. Ithaca College had a great facility with good parking that met our needs. Ithaca College has been a tremendous partner in making the School a success in its 32 years on South Hill. Below are some highlights and details for this year's School. When you see me in June, ask about why I was part of a band playing to a tree in 1987. - David Orr

The Highway School features morning general sessions on a variety of topics from leading industry speakers and 24-28 afternoon workshops lasting 75 minutes each. Over 700 participants, the majority being local highway and public works officials, attend the Highway School every year.

Some of the 2019 School Topics

- *Dealing with Water & Drainage*
- *Winter Maintenance & Snow Plowing*
- *The Relationship between the Board and Superintendent*
- *Local Roads Safety Plans*
- *Pavement Preservation*
- *Worker Safety*
- *Utilities in ROW*
- *CHIPS and other Funding Sources*
- *Legal Panel*

* The agenda will be posted at <https://www.clrp.cornell.edu/trainingevents/highwayschool.html> as it is finalized

Awards and Recognition

The Highway School hosts a variety of events and ceremonies that highlight commitments to achieving excellence in training and education or operational achievements in areas like safety or innovation. This year is no exception!

• Highway School Attendance Awards

The Attendance Awards recognize those who have attended the conference for multiple consecutive years including 5, 10, 15, and 20 year awards. This year we should even have a 40 year award! These prestigious awards are presented on stage the last day of Highway School. Recipients receive a press release and photo with their award.



• Roads Scholar Awards

The Roads Scholar Award recognizes outstanding participation of highway personnel at the Highway School. The award was given out from 1963-1998 (see below for history) and restarted in 2015. The award is given out by county and accounts for attendance by all municipalities in the county:

• 2019 Build a Better Mousetrap Awards

New in 2019, we will be presenting the state of NY winners of our second Build a Better Mousetrap competition at Highway School. All Build a Better Mousetrap innovation entries will be highlighted and the winners will be submitted to a national competition.

• 2019 Work Zone Safety Package Awards

The Cornell Local Roads Program received funds allowing us to provide a limited number of work zone safety packages to local departments. We are pleased to be able to announce the recipients of those packages at this year's highway school.

Continued from Page 3

requirements. While employers can use training videos they must still provide employees with a “mechanism for feedback.”¹⁰ In addition, the State advises that employers may want to consider including in their training program “additional interactive activities such as...an opening activity, role playing or group discussion(s).”¹¹

Access to the State’s power point presentation and video can be found here: <https://www.ny.gov/combating-sexual-harassment-workplace/employers>. It is not required that employers utilize the training aids produced by the State.

Municipalities may adopt and implement their own personalized training program if they choose. Even though employers have until **October 9, 2019** to complete the first round of employee training, we encourage villages and cities to begin their training program as soon as possible.

Endnotes

1. <https://www.governor.ny.gov/news/governor-cuo-mo-releases-finalized-materials-and-guidance-new-yorks-sexual-harassment-prevention>.
2. Id.
3. <https://www.ny.gov/combating-sexual-harassment-workplace/employers>.
4. <https://www.ny.gov/combating-sexual-harassment-workplace/combating-sexual-harassment-frequently-asked-questions#for-employers>.
5. <https://www.ny.gov/sites/ny.gov/files/atoms/files/sexualHarassmentPreventionToolkitforEmployers.pdf>.
6. <https://www.ny.gov/combating-sexual-harassment-workplace/combating-sexual-harassment-frequently-asked-questions#for-employers>.
7. <https://www.ny.gov/sites/ny.gov/files/atoms/files/sexualHarassmentPreventionToolkitforEmployers.pdf>.
8. Id.
9. Id.
10. Id.
11. Id.

Mumblings from the Troll under the Bridge

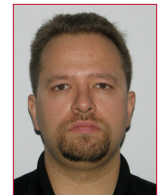

Nick Kuzmik, Special Projects Coordinator

Something new in this fall’s Stormwater and Drainage classes is a demonstration of check dams in action. Small dams can slow water as it travels down slope, allowing it to percolate into the soil and reducing damage from erosion and scour. Development is underway, using CAD and 3D printing techniques to quickly model, test and discard different ideas.

This project has been through one major change and two more revisions. The final version will be made from rugged, clear Lucite and measure almost 20 inches long.

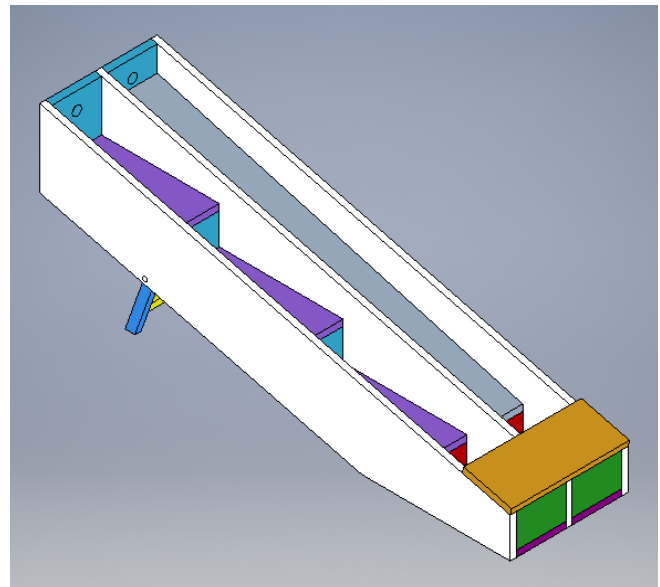

The Highway Super



I'LL GET THE CREW TO FILL THAT POTHOLE ASAP!

MEANWHILE; BACK ON MAIN STREET....



CREW DOING THROW AND GO ...

ITS QUICK FAST AND EASY, BUT



THE NEXT DAY ...

YES, WE FILLED THAT POTHOLE YESTERDAY

WHY DID THE PATCH NOT STAY?

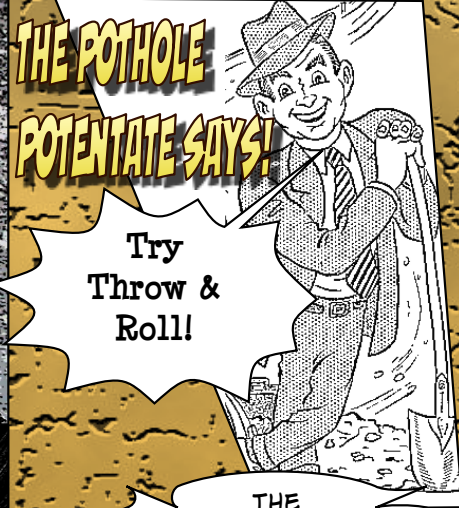

THE POTHOLE POTENTATE SAYS!

Try Throw & Roll!

THROW & ROLL



SWEEP... ...FILL... ...ROLL... ...DONE

... OUT THE WATER..

... WITH POLYMER MIX...

... WITH THE TRUCK TIRE...

... UNTIL YOU DO A PERMENT REPAIR

THE POTHOLES HAVE STAYED FILLED ALL SPRING!

YOU'RE WELCOME!



Cornell Local Roads Program
New York LTAP Center

www.clrp.cornell.edu

Nuggets & Nibbles is a publication of the Cornell Local Roads Program and is published quarterly with the assistance and financial support of the New York State Department of Transportation, the Federal Highway Administration Local Technical Assistance Program (LTAP), and Cornell University.

CLRP STAFF:

David Orr, PE

Director

Melissa Foley

Program Manager

Geoffrey Scott, PE

Technical Assistance Engineer

Amanda Link

Events Coordinator

Adam Howell

Communications Specialist

Barbara Lockwood

Administrative Assistant

Nick Kuzmik

Special Projects Coordinator

Cornell Local Roads Program

416 Riley-Robb Hall

Cornell University

Ithaca, NY 14853-5701

Phone: (607) 255-8033

Fax: (607) 255-4080

Email: clrp@cornell.edu

Website: clrp.cornell.edu

Facebook: [CornellLocalRoads](https://www.facebook.com/CornellLocalRoads)

Twitter: [@local_roads](https://twitter.com/local_roads)

The content and accuracy of this newsletter are the exclusive responsibility of the Cornell Local Roads Program.

Cornell Local Roads Program

416 Riley-Robb Hall, Ithaca, NY 14853

t. 607-255-8033

f. 607-255-4080

clrp@cornell.edu

www.clrp.cornell.edu



New York LTAP Center

Non-Profit
Organization
U.S. Postage
PAID
Cornell University

Cornell Local Roads Program Mission Statement

Improving the Quality and Safety of NYS Highways

The Cornell Local Roads Program provides unbiased, timely and exceptional technical assistance and training to highway and public works departments across New York State to help improve the quality and safety of roads and streets. We support local communities through strong collaborations with partners that enhance the sustainability of local highway assets.

CLRP Publications Request Form

For best results, download and fill out this form.

Date: _____

Last 4 digits of SSN: _____ (for record keeping purposes only)

First name: _____ MI: ____ Last name: _____ Suffix: _____

Job Title: _____

Organization name: _____

Mailing address: _____

City: _____ State: NY Zip: _____

Phone: _____ Ext: _____ Cell Phone: _____

Fax: _____ E-mail: _____

Join the mailing list Email only Newsletter only Already on No thanks

Are you a new Primary Highway Official? Yes No

If so, whom did you replace? _____

Publications

These publications are available in PDF format at <https://www.clrp.cornell.edu/library/publications.html>

Quantity Workshop Manuals:

- _____ A Highway Department's Legal Liabilities
- _____ Asphalt Paving Principles
- _____ Local Roads (and Streets) Done Right
- _____ Pavement Maintenance
- _____ Powers and Duties of Local Highway Officials
- _____ Road Safety Fundamentals
- _____ Roadway and Roadside Drainage
- _____ Running Your Highway Department
- _____ Snow and Ice Control
- _____ Stormwater Management
- _____ Surveying
- _____ Traffic Signs & Pavement Markings
- _____ Work Zone Traffic Control for Local Roads

Quantity Other Publications:

- _____ Video Catalog
- _____ Drainage Law and Drainage Situations and Problems in NYS
- _____ Guidelines for Rural Town and County Roads
- _____ Highway Standards for Low-Volume Roads
- _____ CLRP Program Services Guide
- _____ Traffic Sign Handbook for Local Roads
- _____ Inspectors Job Guide (Pocket Guide)
- _____ Flagger's Handbook (Pocket Guide)
- _____ Work Zone Safety (Pocket Guide)

M5

Cornell Local Roads Program

416 Riley-Robb Hall, Ithaca, NY 14853

t. 607-255-8033

f. 607-255-4080

clrp@cornell.edu

www.clrp.cornell.edu



New York LTAP Center

12/11/18



2019 Highway School Registration Form



June 3-5 2019
Ithaca College
Ithaca, NY

First Name: _____ MI: _____ Last: _____

Title: _____

Organization: _____

- Town Village State Agency County City
 Other: _____

Mailing Address: _____

City: _____ State: _____ Zip Code: _____ County: _____

Daytime Phone: _____ Ext: _____ Fax: _____

E-mail: _____

Is this your first time attending Highway School?

Have you received an award certificate for 20 + years (or more) of Highway School attendance?

(If yes, registration fee is waived)

Early registration fee before May 17 is \$110.00

Attendees registering after May 17 must register on-site at a fee rate of \$150.00.

Please Note: Cancellations received 10 days prior to event will be refunded minus a \$10.00 processing fee. No refunds will be given after the 10 day cancellation deadline.

Check in and on-site registration will be available Sunday, June 2 from 3 - 5 p.m.
Contact Executive Meeting Coordinator Patty Kebea with any questions at 518-465-7933

Please email completed forms to: pkebea@nytowns.org

Or send to:
Association of Towns
150 State Street
Albany, New York 12207
Phone: (518) 465-7933
Fax: (518) 465-0724

2019 Highway School Registration & Conference Information

June 3-5 2019

Ithaca College

Sponsored by The Association of Towns of the State of New York
and
The Cornell Local Roads Program

Registration

Early registration fee before May 17: \$110.00. Attendees registering after May 17 must register on-site at a fee rate of \$150.00.

Please Note: Cancellations received 10 days prior to event will be refunded minus a \$10.00 processing fee. No refunds will be given after the 10 day cancellation deadline.

Registration forms and checks made payable to the Association of Towns can be mailed to:
Association of Towns, 150 State street, Albany, New York 12207

Attendees can also register online and pay at www.nytowns.org. Online registrants will receive an email confirmation following payment acceptance. Only Visa and Mastercard are accepted.

On-Site Registration and early check-in is available between 3 and 5 p.m. on Sunday June 2 in the North Foyer of Philips Hall on the Ithaca College Campus. Conference Check-in will resume Monday June 3 at 8 a.m.

2019 Highway School Topics

Dealing with Water & Drainage
Winter Maintenance & Snow Plowing
Emergency Response: Extreme Events, Accidents
Local Roads Safety Plans
Pavement Preservation
Worker Safety Discussion Panel
Utilities in ROW
CHIPS and Other Funding Sources

Conference Information

- **Meals:** Lunch will be provided at the conference on Monday and Tuesday.
- **Parking:** Parking is available in designated lots on the Ithaca College Campus with a valid parking permit. Parking permits will be provided by conference staff on Monday morning at the entrance of the parking areas. If you require handicapped parking, please bring your own handicapped parking permit. There are a limited number of handicapped spaces available.
- **Expenses:** Actual and necessary expenses incurred while attending Highway School, including the registration fee, are proper municipal charges under Town Law, §116(12) and General Municipal Law, §77(b).
- **Credits For Attendance:** Attendees will automatically receive three credits in the highway category of the Association of Town's Certified Town Official Program. Attendees enrolled in the Cornell Local Roads Roadmaster Program will also receive credit towards Road Master levels III and IV when they earn their 5 or 10 year attendance awards.

Contact Patty Kebea, Executive Meeting Coordinator, at the Association of Towns with questions at (518) 465-7933.

Stay up to date with current information about the 2019 Highway School on the web at:
Association of Towns - www.nytowns.org
Cornell Local Roads Program - clrp.cornell.edu

2019 Engineering Workshop Registration Form

Registration Fee: \$75.00 per person per workshop and PDH fees are an additional \$20.00

Hydraulic Design of Culverts - 7 PDHs

June 18—Steuben Co June 19—Schoharie Co

Design and Maintenance of Slopes using Geosynthetics - 8 PDHs

July 16—Ontario Co July 17—Oneida Co July 18—Westchester Co

Americans with Disabilities Act in the Public Right of Way - 7 PDHs

August 6—Saratoga Co August 7—Dutchess Co August 8—Suffolk Co

Low-Volume Road Pavement Design - 7 PDHs

October 8—Genesee Co October 9—Tompkins Co October 10—Rockland Co

Today's Date: _____

Registrant #1 PDH? Yes No

Last 4 digits of SSN: _____ (optional) Special dietary request? _____

First name: _____ MI: _____ Last name: _____ Suffix: _____

Title: _____ Organization: _____

Mailing address: _____

City: _____ State: _____ Zip: _____

Phone #: _____ Ext: _____ Cell Phone: _____

Fax #: _____ Email: _____

Are you a new highway or public works official? Yes No
 Add me to the CLRP mailing list Already on mailing list Email only Newsletter only No thanks

Registrant #2 PDH? Yes No

Last 4 digits of SSN: _____ (optional) Special dietary request? _____

First name: _____ MI: _____ Last name: _____ Suffix: _____

Title: _____ Email: _____

Add me to the CLRP mailing list Already on mailing list Email only Newsletter only No thanks

Registrant #3: PDH? Yes No

Last 4 digits of SSN: _____ (optional) Special dietary request? _____

First name: _____ MI: _____ Last name: _____ Suffix: _____

Title: _____ Email: _____

Add me to the CLRP mailing list Already on mailing list Email only Newsletter only No thanks

For best results, download and fill out this form.

NOTE: Attendees must stay for the entire workshop to earn PDHs.

M5

2019 Engineering Workshops



Hydraulic Design of Culverts

Steuben County - June 18th

Steuben County Civil Defense Training Center
7220 State Rt 54
Bath, NY 14810

Schoharie County - June 19th

Schoharie County Office Building
284 Main Street
Schoharie, NY 12157



Design and Maintenance of Slopes using Geosynthetics

Ontario - July 16th

Ontario County Cooperative Extension
480 N Main Street
Canandaigua, NY 14424

Oneida - July 17th

Mohawk Valley Community College
Information Technology Building
1101 Sherman Dr
Utica, NY 13501

Westchester - July 18th

Westchester Fire Training Center
4 Dana Road
Valhalla, NY 10595



Americans with Disabilities Act in the Public Right of Way

Saratoga - August 6th

Saratoga County Cooperative Extension
50 West High Street
Ballston Spa, NY 12020

Dutchess County - August 7th

Dutchess County Dept. of Behavioral & Community Health
230 North Rd
Poughkeepsie, NY 12601

Suffolk County - August 8th

Suffolk County DPW Building
335 Yaphank Ave
Yaphank, NY 11980



Low-Volume Road Pavement Design

Genesee County - October 8th

Genesee County Emergency Service Building
7690 State Street Rd
Batavia, NY 14020

Tompkins - October 9th

Tompkins County Cooperative Extension
615 Willow Ave
Ithaca, NY 14805

Rockland - October 10th

Rockland County Fire Training Center
35 Firemens Memorial Drive
Pomona, NY 10970

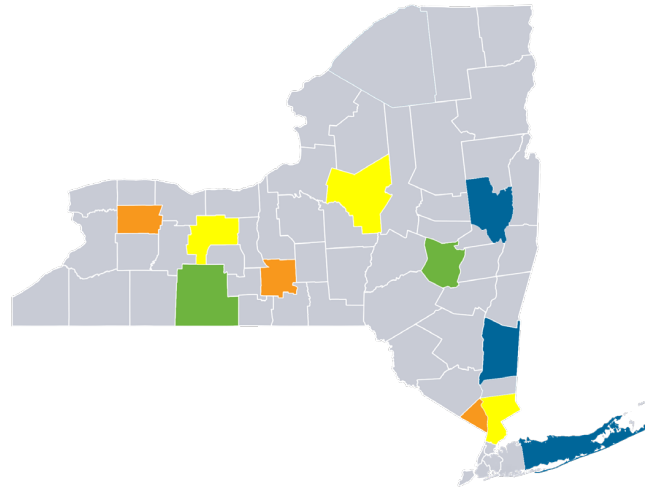

Registration

Complete this form and mail, email (clrp@cornell.edu), or fax (607-255-4080) it to us.

We accept check or voucher made payable to "Cornell Local Roads Program." To pay by credit card please call for details. You will receive a confirmation letter and a map to the workshop site. If you have not received a confirmation at least one week before the workshop, please call (607) 255-8033 or email.

Workshop Timing/Food

Engineering workshops typically run from 8:00 am to 4 pm. Sign-in starts at 7:30 am. Coffee, refreshments, lunch and course materials are included.

Cancellations

If you must cancel your registration, please call us at least 3 business days prior to the workshop date. Someone may substitute for you at any time.

The Cornell Local Roads Program is sponsored jointly by:

- The Federal Highway Administration
- New York State Department of Transportation
- Cornell University

Spring 2019 Workshop Registration Form

Registration Fee: \$50 per person per workshop For best results, download and fill out this form

Traffic Signs & Pavement Markings

March 26—Herkimer Cty March 27—Greene Cty March 28—Putnam Cty
 April 2—Cortland Cty April 3—Steuben Cty April 4—Niagara Cty

Identifying and Reducing Legal Liability: A Guide for Highway and Public Works Departments

April 16—Suffolk Cty April 17—Dutchess Cty April 18—Delaware Cty

Asphalt Paving Principles

April 23—Clinton Cty April 24—Saratoga Cty April 25—Ulster Cty
 May 14—Oswego Cty May 15—Yates Cty May 16—Erie Cty

Roadway and Roadside Drainage

April 23—Orleans Cty April 24—Seneca Cty April 25—Broome Cty
 May 14—Schoharie Cty May 15—Washington Cty May 16—St. Lawrence Cty

Surveying

May 7—Wyoming Cty May 8—Tioga Cty May 9—Sullivan Cty

Today's Date: _____

Registrant #1

Last 4 digits of SSN: _____ (optional) Special dietary request? _____
First name: _____ MI: _____ Last name: _____ Suffix: _____
Title: _____ Organization: _____
Mailing address: _____
City: _____ State: _____ Zip: _____
Phone #: _____ Ext: _____ Cell Phone: _____
Fax #: _____ Email: _____

Are you a new highway or public works official? Yes No
Name of outgoing highway or public works official: _____

Is the person leaving the position staying within the agency? Yes No
If Yes, what is their new title? _____

Add me to the CLRPP mailing list Already on mailing list Email only Newsletter only No thanks

Registrant #2

Last 4 digits of SSN: _____ (optional) Special dietary request? _____
First name: _____ MI: _____ Last name: _____ Suffix: _____
Title: _____ Email: _____

Add me to the CLRPP mailing list Already on mailing list Email only Newsletter only No thanks

Registrant #3:

Last 4 digits of SSN: _____ (optional) Special dietary request? _____
First name: _____ MI: _____ Last name: _____ Suffix: _____
Title: _____ Email: _____

Add me to the CLRPP mailing list Already on mailing list Email only Newsletter only No thanks

Spring 2019 Workshops

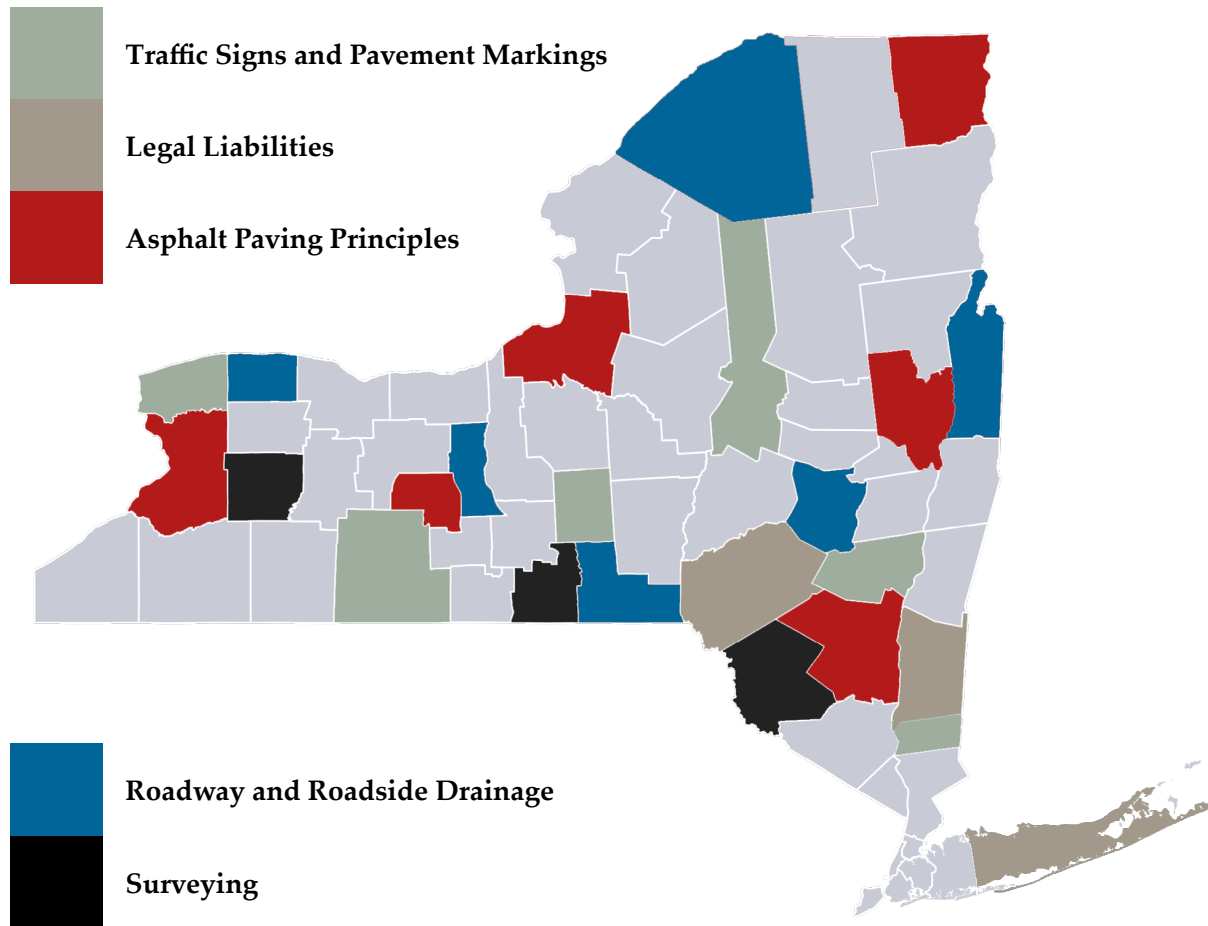

Registration

Complete this form and mail, email (clrp@cornell.edu), or fax (607-255-4080) it to us.

Each regular workshop is \$50 per session per registrant. Engineering workshops may be more and include the option to pay for PDH credits. We accept check or voucher made payable to "Cornell Local Roads Program." To pay by credit card please call for details. You will receive a confirmation letter and a map to the workshop site. If you have not received a confirmation at least one week before the workshop, please call (607) 255-8033 or email.

Workshop Timing/Food

Workshops typically run from 8:30 am to 3 pm. Sign-in starts at 8 am. Coffee, refreshments, lunch and course materials are included. Please contact us if you have any special dietary requirements.

Cancellations

If you must cancel your registration, please call us at least 3 business days prior to the workshop date. This allows us to adjust our food order or offer your place to someone on our waiting list. Of course, someone may substitute for you at any time.

The Cornell Local Roads Program is sponsored jointly by:

- The Federal Highway Administration
- New York State Department of Transportation
- Cornell University